



## Ditec DOD

# Industrial sectional door automations

(Original instructions)

IP1733EN  
Technical manual

# Index

Subject		Page
1.	<b>General safety precautions</b>	33
2.	<b>Declaration of incorporation of partly completed machinery</b>	35
2.1	Machinery directive	35
3.	<b>Technical data</b>	36
3.1	Applications	36
4.	<b>DOD12-14-15 axle installation</b>	37
4.1	Overall dimensions	38
4.2	Motor installation	38
4.3	Installation	39
4.4	Installation DODMA	40
5.	<b>DOD12-14-15 chain link-up installation</b>	41
5.1	Motor chain link-up	43
5.2	Installation	44
6.	<b>Cord release installation</b>	45
7.	<b>Ditec DOD 12-14-15 sliding door configuration</b>	46
8.	<b>Ditec DOD 12-14-15 + DODTC1 sliding door configuration</b>	47
9.	<b>Ditec DOD 12-14-15 folding door configuration</b>	48
10.	<b>Electrical connections</b>	49
10.1	Limit-switch adjustment	50
10.2	DOD14PS electrical connections	51
11.	<b>Routine maintenance plan</b>	52
	Operating instructions	53

## Caption



This symbol indicates instructions or notes regarding safety, to which special attention must be paid.



This symbol indicates useful information for the correct functioning of the product.

# 1. General safety precautions



Failure to respect the information given in this manual may cause personal injury or damage to the device.

Keep these instructions for future reference

This installation manual is intended for qualified personnel only.

Installation, electrical connections and adjustments must be performed by qualified personnel, in accordance with Good Working Methods and in compliance with the current regulations.

Read the instructions carefully before installing the product.

Bad installation could be dangerous.



The packaging materials (plastic, polystyrene, etc.) should not be discarded in the environment or left within reach of children, as they are a potential source of danger.

Before installing the product, make sure it is in perfect condition.

Do not install the product in explosive areas and atmospheres: the presence of inflammable gas or fumes represents a serious safety hazard.

Before installing the motorisation device, make all the necessary structural modifications to create safety clearance and to guard or isolate all the crushing, shearing, trapping and general hazardous areas.

Make sure the existing structure is up to standard in terms of strength and stability. The motorisation device manufacturer is not responsible for failure to observe Good Working Methods when building the frames to be motorised, or for any deformation during use.

The safety devices (photocells, safety edges, emergency stops, etc.) must be installed taking into account: applicable laws and directives, Good Working Methods, installation premises, system operating logic and the forces developed by the motorised door or gate.

The safety devices must protect against crushing, cutting, trapping and general danger areas of the motorised door or gate.



Display the signs required by law to identify hazardous areas.

Each installation must bear a visible indication of the data identifying the motorised door or gate.

When necessary, connect the motorised door or gate to an effective earthing system that complies with the current safety standards.

During installation, maintenance and repair operations, cut off the power supply before opening the cover to access the electrical parts.



The automation protection casing must be removed by qualified personnel only.

The electronic parts must be handled using earthed antistatic conductive arms. The manufacturer of the motorisation declines all responsibility if component parts not compatible with safe and correct operation are fitted.

Only use original spare parts for repairing or replacing products.

The installer must supply all information concerning the automatic, manual and emergency operation of the motorised door or gate, and must provide the user with the operating instructions.

# General safety precautions for the user

 These precautions are an integral and essential part of the product and must be supplied to the user.

Read them carefully since they contain important information on safe installation, use and maintenance.

These instructions must be kept and forwarded to all possible future users of the system.

This product must only be used for the specific purpose for which it was designed.

Any other use is to be considered improper and therefore dangerous. The manufacturer cannot be held responsible for any damage caused by improper, incorrect or unreasonable use.

Avoid operating in the proximity of the hinges or moving mechanical parts. Do not enter within the operating range of the motorised door or gate while it is moving.

Do not obstruct the motion of the motorised door or gate, as this may cause a dangerous situation.

The motorised door or gate may be used by children over the age of 8 and by people with reduced physical, sensorial or mental abilities, or lack of experience or knowledge, as long as they are properly supervised or have been instructed in the safe use of the device and the relative hazards.

Children must be supervised to make sure they do not play with the device, nor play/remain in the sphere of action of the motorised door or gate.

Keep remote controls and/or any other command devices out of the reach of children, to avoid any accidental activation of the motorised door or gate.

In the event of a product fault or malfunction, turn off the power supply switch. Do not attempt to repair or intervene directly, and contact only qualified personnel.

Failure to comply with the above may cause a dangerous situation.

Any repair or technical intervention must be carried out by qualified personnel.

Cleaning and maintenance work must not be carried out by children unless they are supervised.

To ensure that the system works efficiently and correctly, the manufacturer's indications must be complied with and only qualified personnel must perform routine maintenance on the motorised door or gate. In

particular, regular checks are recommended in order to verify that the safety devices are operating correctly.

All installation, maintenance and repair work must be documented and made available to the user.

Only lock and release the door wings when the motor is switched off.



Do not enter within the operating range of the wing.

To dispose of electrical and electronic equipment correctly, users must take the product to special "recycling centres" provided by the municipal authorities.

## 2. Declaration of incorporation of partly completed machinery

(Directive 2006/42/EC, Annex II-B)

The manufacturer Entrematic Group AB with headquarters in Lodjursgatan 10, SE-261 44 Landskrona, Sweden

declares that the automation system for Ditec DOD sectional doors:

- has been constructed to be installed on a manual door to construct a machine pursuant to the Directive 2006/42/EC. The manufacturer of the motorized door shall declare conformity pursuant to the Directive 2006/42/EC (annex II-A), prior to the machine being put into service;
- conforms to applicable essential safety requirements indicated in annex I, chapter 1 of the Directive 2006/42/EC;
- conforms to the Low Voltage Directive 2006/95/EC;
- conforms to the Electromagnetic Compatibility Directive 2004/108/EC;
- technical documentation conforms to Annex VII-B to the Directive 2006/42/EC;
- technical documentation is managed by Marco Pietro Zini with offices in Via Mons. Banfi, 3 - 21042 Caronno Pertusella (VA) - ITALY;
- a copy of technical documentation will be provided to national competent authorities, following a suitably justified request.

Landskrona, 15-07-2013

Marco Pietro Zini  
(BA President)

### 2.1 Machinery Directive

Pursuant to Machinery Directive (2006/42/EC) the installer who motorizes a door or gate has the same obligations as the manufacturer of machinery and as such must:

- prepare the technical file which must contain the documents indicated in Annex V of the Machinery Directive;  
(The technical file must be kept and placed at the disposal of competent national authorities for at least ten years from the date of manufacture of the motorized door);
- draw up the EC Declaration of Conformity in accordance with Annex II-A of the Machinery Directive and deliver it to the customer;
- affix the EC marking on the motorized door in accordance with point 1.7.3 of Annex I of the Machinery Directive.

### 3. Technical data

	Ditec DOD 12	Ditec DOD 14	Ditec DOD 15	Ditec DOD 14PS
<b>Power supply</b>	230 V- 50 Hz	230 V- 50 Hz	400 V- 50 Hz	230 V- 50 Hz
<b>Absorption</b>	3 A	3 A	1,2 A	3 A
<b>Motor power</b>	350 W	350 W	450 W	350 W
<b>Torque</b>	45 Nm	60 Nm	65 Nm	60 Nm
<b>Revolution transmission shaft</b>	32 RPM	22 RPM	32 RPM	22 RPM
<b>Capacitor</b>	25 µf	22 µf	-	22 µf
<b>Service class</b>	4 - INTENSIVE	4 - INTENSIVE	4 - INTENSIVE	
<b>Min. number consecutive cycles</b>	50	50	50	
<b>Intermittence</b>	S2 = 30 min S3 = 50%	S2 = 30 min S3 = 50%	S2 = 30 min S3 = 50%	
<b>Temperature</b>	-20° C - +55° C -35° C - +55° C with NIO enabled	-20° C - +55° C -35° C - +55° C with NIO enabled	-20° C - +55° C	-20° C - +55° C
<b>Degree of protection</b>	IP40	IP40	IP40	IP40
<b>Weight</b>	15 kg	15 kg	15 kg	15 kg
<b>Control panel</b>	E1A	E1A	E1T	-

#### 3.1 Application

Service class: 4 (minimum 100 cycles a day for 10 years or 200 cycles a day for 5 years)

Use: INTENSIVE (For pedestrian accesses with intensive use).

- The operating performance specifications refer to the recommended weight (about 2/3 of maximum allowed weight). Use with maximum allowed weight could reduce the above performance specifications in technical data.
- The service class, operating times and number of consecutive cycles are merely approximate. These have been statistically determined in average conditions of use and are not certain for each single case.
- Each automatic entrance features variable factors such as: friction, balancing and environmental conditions that can substantially change both the duration and operating quality of the automatic entrance or part of its components (including automatic system). It is up to the installer to adopt adequate safety coefficients for each single installation.



**ATTENTION:** DOD12, DOD14 and DOD15 geared motors may be used for operating sectional doors only if correctly balanced.

The sectional doors can only be manually moved by means of a handle (installing the DODSBV release device) or a chain (installing the DODSBC release device).



The given operating and performance features can only be guaranteed with the use of ENTREMATIC accessories and safety devices.

## 4. Ditec DOD 12 - 14 -15 axle installation

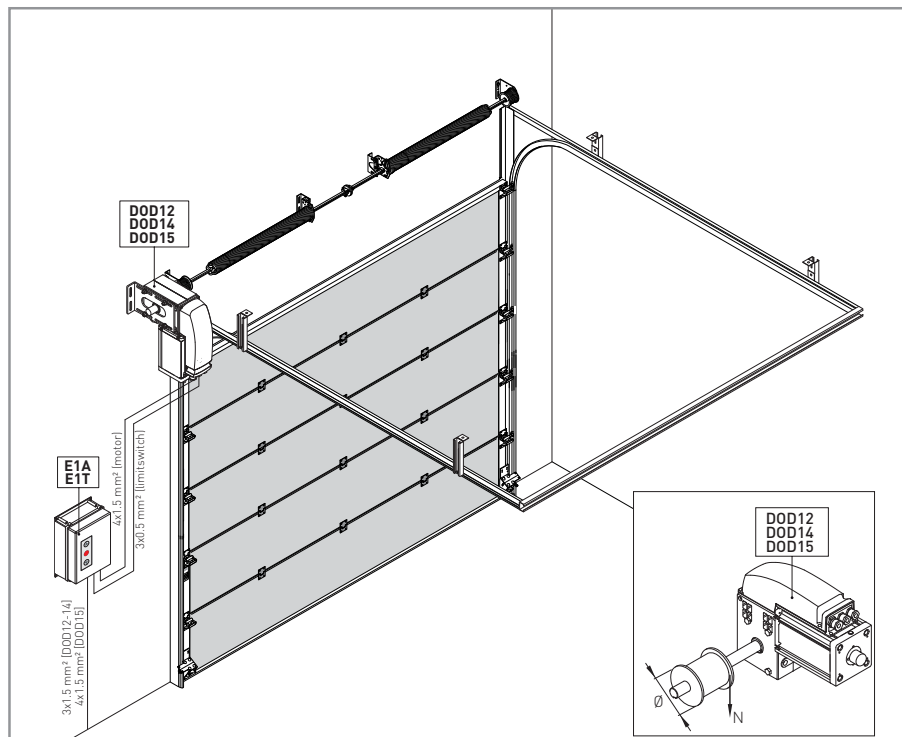

**WARNING:** For correct operation we advise to move the door at a speed lower than 0.2 m/s.

Type	Pinion	Crown	Reduction ratio	Torque [Nm]	Rotating speed [RPM]	Door cable pulley [Ø mm]	Door speed [m/s]	Max Run [m]	Max force [N]
DOD 12	-	-	1:1	45	32	102	0,17	8,7	706
						124	0,21	10,6	581
						158	0,26	13,6	456
						226	0,38	19,4	319
						Ø	=Ø:597	=Ø:11,66	=72000:Ø
DOD 14	-	-	1:1	60	22	102	0,12	8,7	941
						124	0,14	10,6	774
						158	0,18	13,6	608
						226	0,26	19,4	425
						Ø	=Ø:868	=Ø:11,66	=96000:Ø
DOD 15	-	-	1:1	65	32	102	0,17	8,7	1020
						124	0,21	10,6	839
						158	0,26	13,6	658
						226	0,38	19,4	460
						Ø	=Ø:597	=Ø:11,66	=104000:Ø

## 4.1 Overall dimensions

Unless otherwise specified, all measurements are expressed in millimetres (mm).

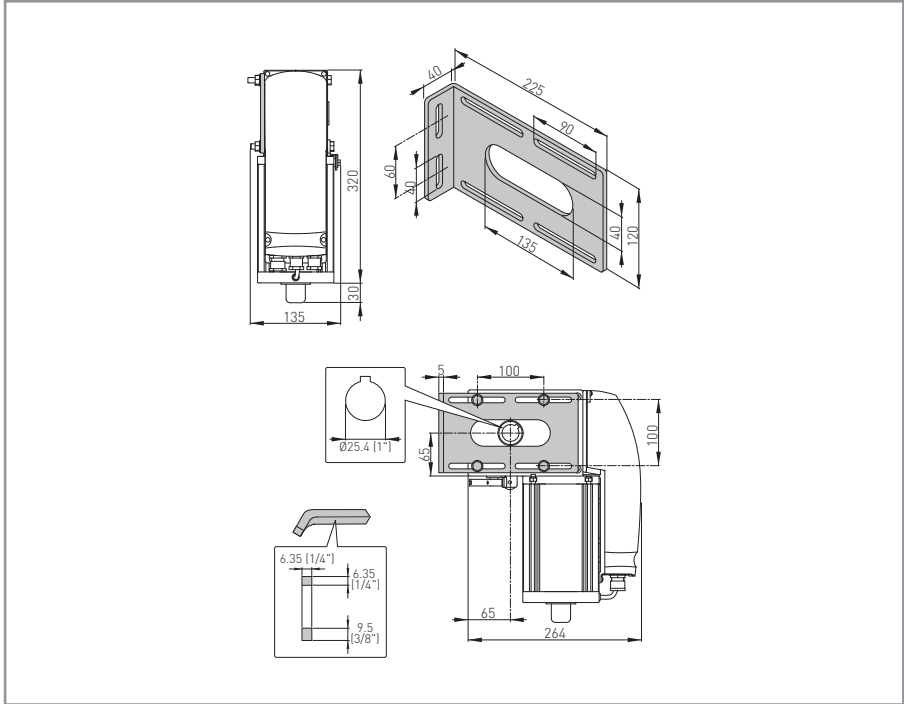

## 4.2 Motor assembling

Mount the DOD12-14-15 motor onto the wall bracket and release idle bracket as shown in figure.

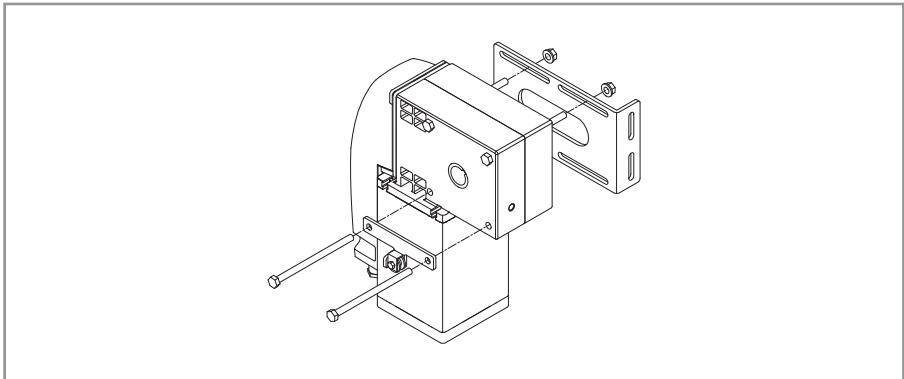



## 4.3 Installation

- Fit the D0D12-14-15 motor onto the drive shaft.
- After having determined the position of the wall bracket, drill the holes and secure the bracket in place with dowels (not supplied).
- Insert the appropriate cotter according to shaft cavity length.
- Secure the metal clamp so as to prevent the risk of the cotter coming out of the shaft.



ATTENTION: firmly tighten down all fastening screws.

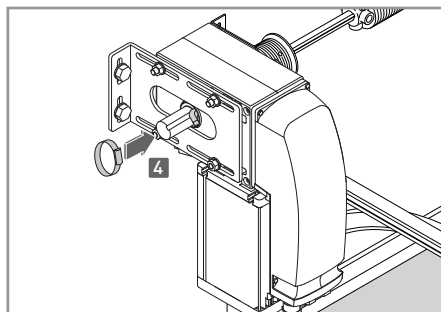
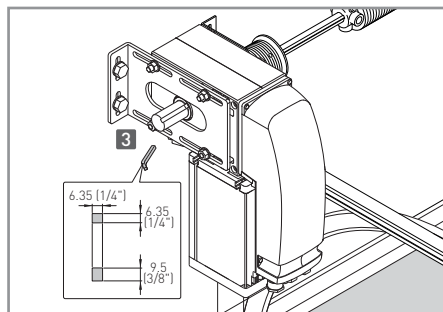
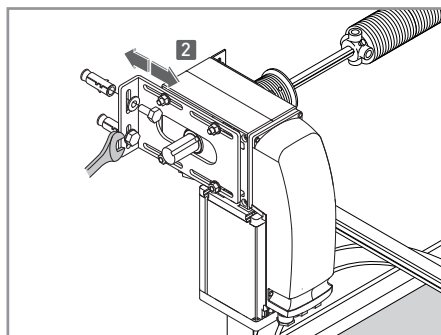
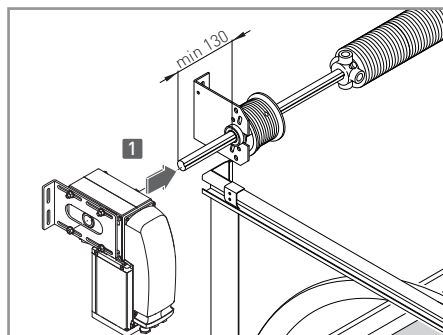

## 4.4 DODMA

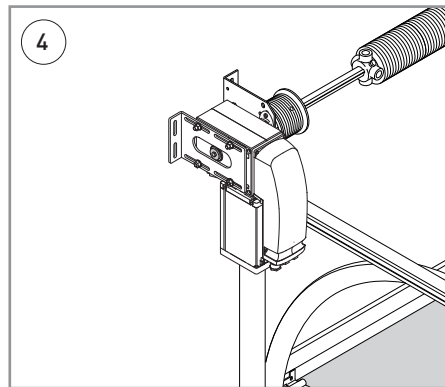
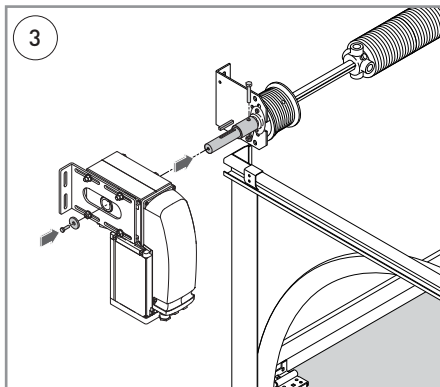
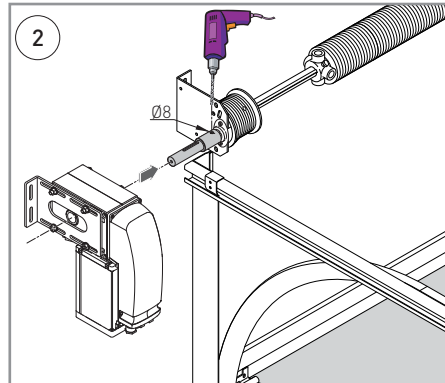
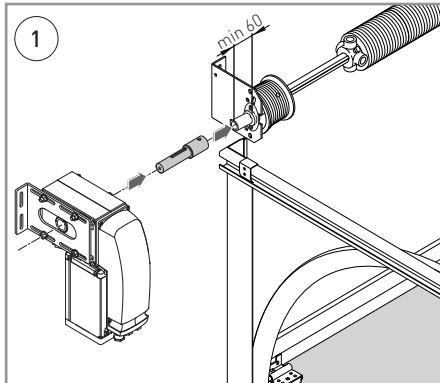
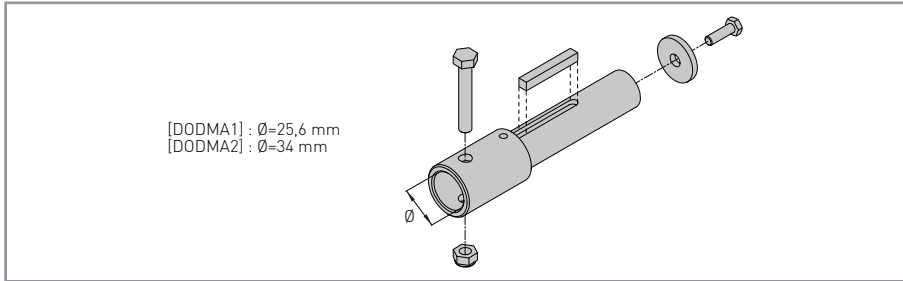

## 5. Ditec DOD 12 - 14 -15 chain link-up installation

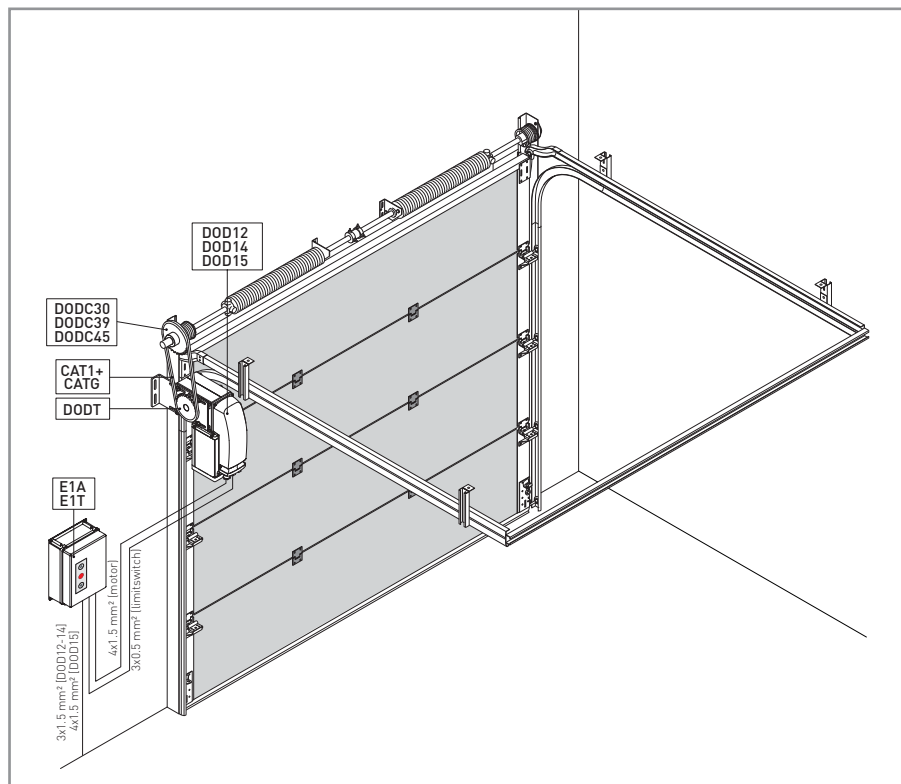

**WARNING:** For correct operation we advise to move the door at a speed lower than 0.2 m/s.

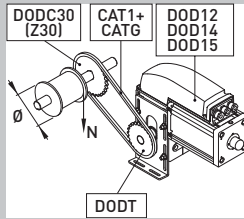

Type	Pinion	Crown	Reduction ratio	Torque [Nm]	Rotating speed [RPM]	Door cable pulley [Ø mm]	Door speed [m/s]	Max Run [m]	Max force [N]
DOD12	DODT (Z24)	DODC30 (Z30)	1:1,25	56	25,6	102	0,14	7,0	882
						124	0,17	8,5	726
						158	0,21	10,8	570
						226	0,30	15,5	398
						Ø	= Ø : 746	= Ø : 14,57	= 90000 : Ø
DOD14	DODT (Z24)	DODC30 (Z30)	1:1,25	75	17,6	102	0,09	7,0	1176
						124	0,11	8,5	968
						158	0,15	10,8	759
						226	0,21	15,5	531
						Ø	= Ø : 1085	= Ø : 14,57	= 120000 : Ø
DOD15	DODT (Z24)	DODC30 (Z30)	1:1,25	81	25,6	102	0,14	7,0	1275
						124	0,17	8,5	1048
						158	0,21	10,8	823
						226	0,30	15,5	575
						Ø	= Ø : 746	= Ø : 14,57	= 130000 : Ø

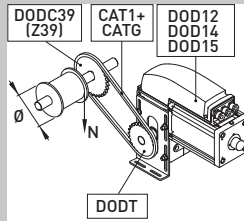

Type	Pinion	Crown	Reduction ratio	Torque [Nm]	Rotating speed [RPM]	Door cable pulley [Ø mm]	Door speed [m/s]	Max Run [m]	Max force [N]
DOD12	DODT (Z24)	DODC39 (Z39)	1:1,625	73	19,7	102	0,11	5,4	1147
						124	0,13	6,5	944
						158	0,16	8,3	741
						226	0,23	11,9	518
						Ø	= Ø : 970	= Ø : 18,95	= 117000:Ø
DOD14	DODT (Z24)	DODC39 (Z39)	1:1,625	98	13,5	102	0,07	5,4	1529
						124	0,09	6,5	1258
						158	0,11	8,3	987
						226	0,16	11,9	690
						Ø	= Ø : 1415	= Ø : 18,95	= 156000:Ø
DOD15	DODT (Z24)	DODC39 (Z39)	1:1,625	106	19,7	102	0,11	5,4	1667
						124	0,13	6,5	1371
						158	0,16	8,3	1076
						226	0,23	11,9	752
						Ø	= Ø : 970	= Ø : 18,95	= 170000:Ø

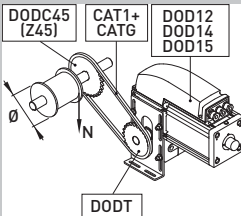

Type	Pinion	Crown	Reduction ratio	Torque [Nm]	Rotating speed [RPM]	Door cable pulley [Ø mm]	Door speed [m/s]	Max Run [m]	Max force [N]
DOD12	DODT (Z24)	DODC45 (Z45)	1:1,875	84	17,1	102	0,09	4,7	1324
						124	0,11	5,7	1089
						158	0,14	7,2	854
						226	0,20	10,3	597
						Ø	= Ø : 1119	=Ø:21,86	=135000:Ø
DOD14	DODT (Z24)	DODC45 (Z45)	1:1,875	113	11,7	102	0,06	4,7	1756
						124	0,08	5,7	1452
						158	0,10	7,2	1139
						226	0,14	10,3	796
						Ø	= Ø : 1632	=Ø:21,86	=180000:Ø
DOD15	DODT (Z24)	DODC45 (Z45)	1:1,875	122	17,1	102	0,09	4,7	1912
						124	0,11	5,7	1573
						158	0,14	7,2	1234
						226	0,20	10,3	863
						Ø	= Ø : 1119	=Ø:21,86	=195000:Ø

## 5.1 Motor-chain link-up

Fasten the wall and release idle brackets to the DOD12-14-15 motor and then fit on the pinion pin (DODT) in the traction position (i.e. on either one of the two sides of the motor).

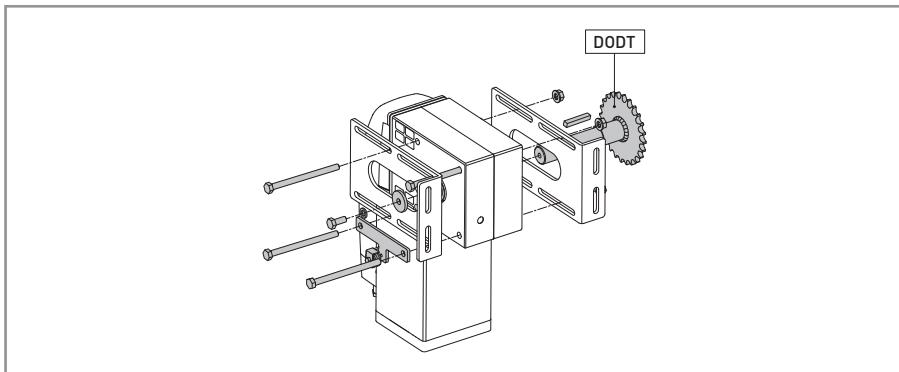

## 5.2 Installation

- After having determined the position of the wall bracket, drill the holes and secure the bracket in place with dowels (not included).
- Fit the crown wheel onto the sectional door shaft and insert the appropriate cotter depending on shaft cavity length. Fasten the metal clamps so as to prevent the risk of the cotter coming out of the shaft.
- Link up crown and pinion by means of the chain. Properly tauten the chain by acting on the wall anchoring brackets. Fix the bracket [A] to avoid that the shaft of the sectional bends and to guarantee the correct tensioning of the chain.



**ATTENTION:** firmly tighten down all fastening screws.

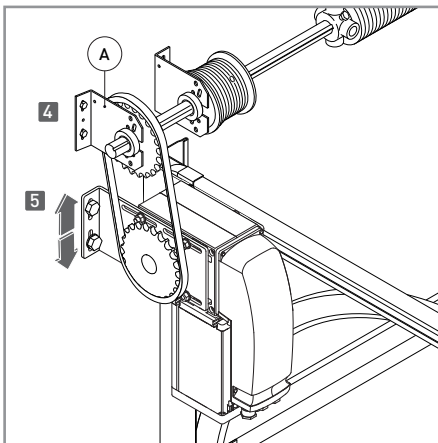
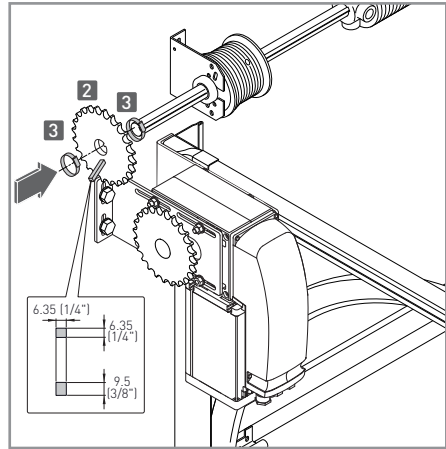
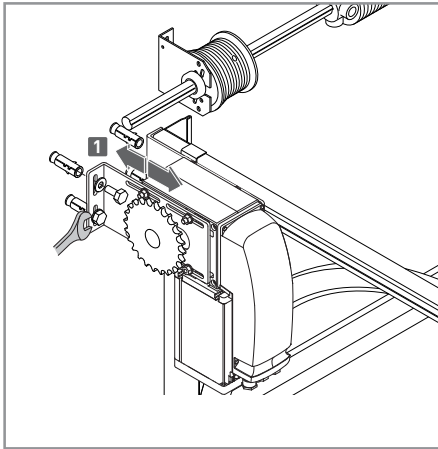

## 6. Cord release installation



The cord release on the sectional doors should only be used by skilled personnel, for adjusting the door balancing springs during the installation and maintenance phases.  
**DO NOT USE TO MOVE THE SECTIONAL DOORS MANUALLY.**

- Fasten the brackets to the gearmotor, then pass the release cord.
- Connect the ring and the handle to the release cord.
- Fasten the cord connection bracket at a height of at least 2.5m from the ground, to avoid any improper use by unauthorised persons. Attach the WARNING label to the motor.

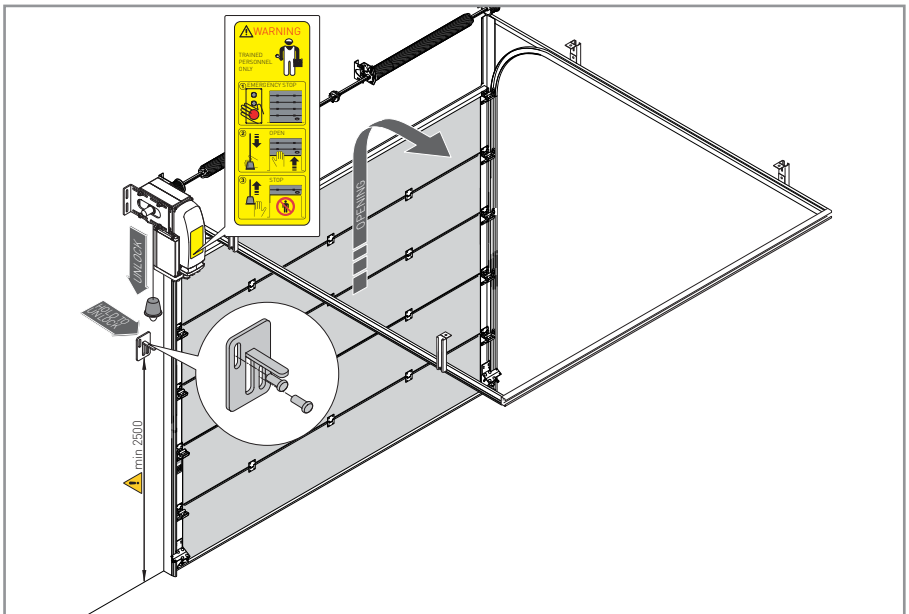
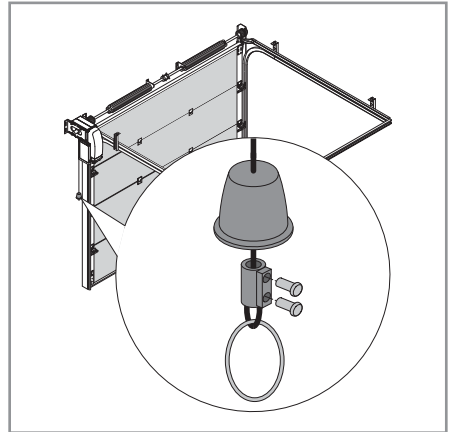
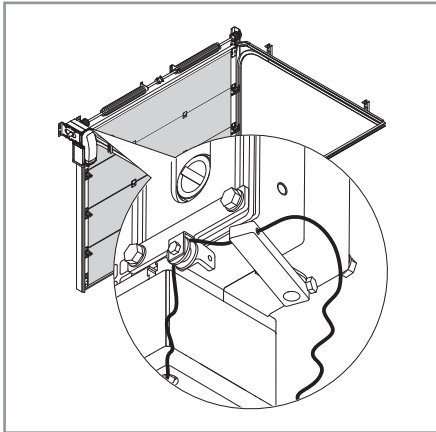

## 7. Ditec DOD 12-14-15 installed on sliding door

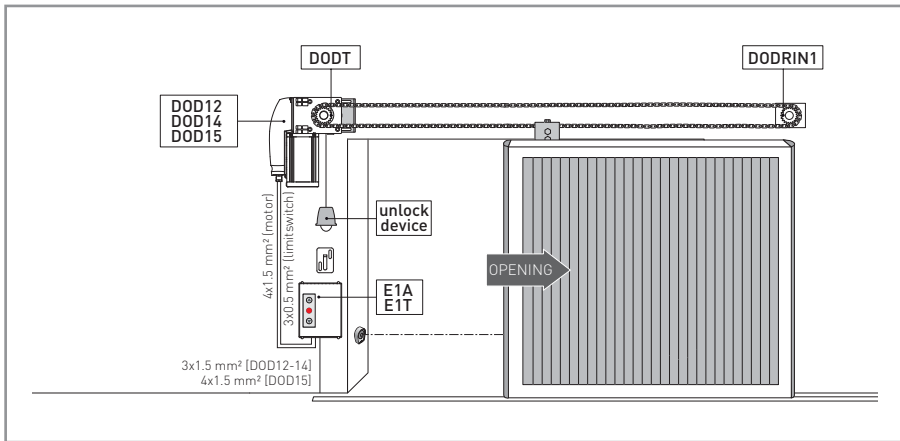

Type	Pinion	Crown	Reduction ratio	Torque [Nm]	Rotating speed [RPM]	Door speed [m/s]	Max Run [m]	Max Force [N]
DOD12	DODT (Z24)	DODRIN1 (Z24)	1:1	45	32	0,16	8,35	900
DOD14	DODT (Z24)	DODRIN1 (Z24)	1:1	60	22	0,11	8,35	1200
DOD15	DODT (Z24)	DODRIN1 (Z24)	1:1	65	32	0,16	8,35	1300



## 8. Ditec DOD 12-14-15 with Ditec DOD TC1 installed on sliding door

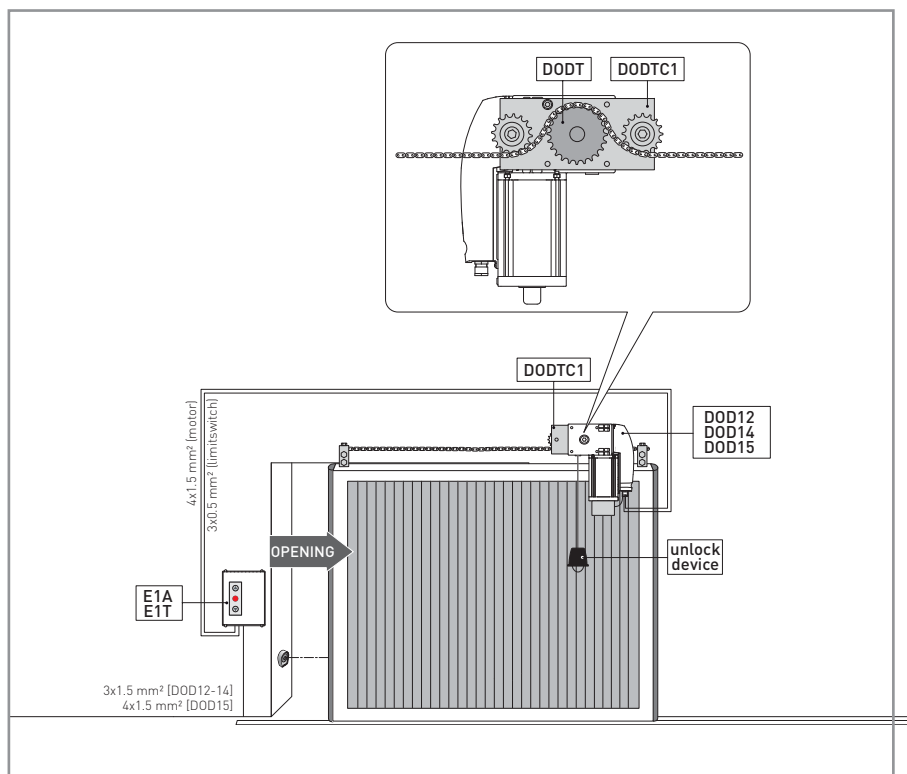

Type	Pinion	Crown	Reduction ratio	Torque [Nm]	Rotating speed [RPM]	Door speed [m/s]	Max Run [m]	Max Force [N]
DOD12	DODT [Z24]	DODTC1 [Z24]	1:1	45	32	0,16	8,35	900
DOD14	DODT [Z24]	DODTC1 [Z24]	1:1	60	22	0,11	8,35	1200
DOD15	DODT [Z24]	DODTC1 [Z24]	1:1	65	32	0,16	8,35	1300

## 9. Ditec DOD 12-14-15 installed on folding doors

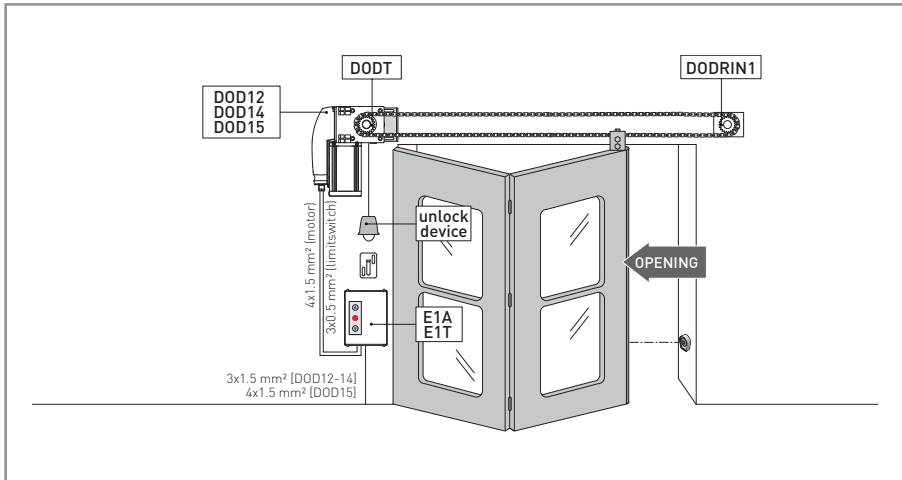

Type	Pinion	Crown	Reduction ratio	Torque [Nm]	Rotating speed [RPM]	Door speed [m/s]	Max Run [m]	Max Force [N]
DOD12	DODT (Z24)	DODRIN1 (Z24)	1:1	45	32	0,16	8,35	900
DOD14	DODT (Z24)	DODRIN1 (Z24)	1:1	60	22	0,11	8,35	1200
DOD15	DODT (Z24)	DODRIN1 (Z24)	1:1	65	32	0,16	8,35	1300



NOTE: for proper operation the door shall be equipped with a derailment device and the chain fastening bracket on the wing must be rotating.

# 10. Ditec DOD 12-14-15 electrical connections

Before connecting the power supply, make sure the plate data correspond to that of the mains power supply.

An omnipolar disconnection switch with minimum contact gaps of 3 mm must be included in the mains supply.

Check that upstream of the electrical installation there is an adequate residual current circuit breaker and a suitable overcurrent cutout.

Wire up the motor to the appropriate electric board terminals.

ATTENTION: make sure to connect the motor ground to the ground point.

Wire up the limit switches to the appropriate electric board terminals.

ATTENTION: (only DOD12-14) set DIP2=OFF on E1A control panel.

Secure the cable using a special cable clamp.

Make sure there are no sharp edges that may damage the power supply cable.

Connection to the mains power supply, in the section outside the automation, is made with independent channels and separated from the connections to the control and safety devices.

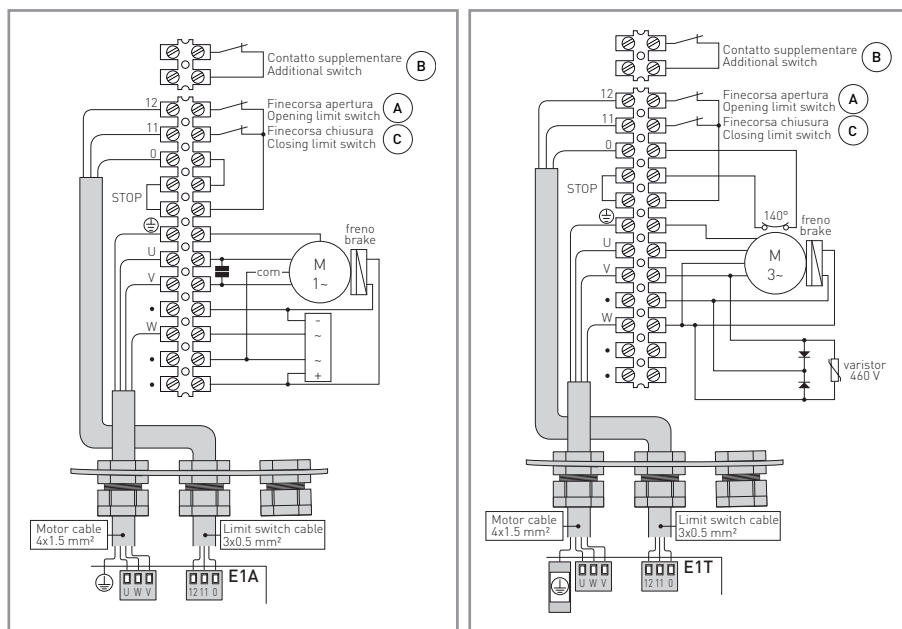

## 10.1 Limit switch adjustment

With door open, adjust screw [A] so as to cause the associated cam to trigger the opening limit switch.

With door closed, adjust screw [C] so as to cause the associated cam to trigger the closing limit switch.

You can decide to adjust the nut [B] so that the relative cam triggers the supplementary contact. **WARNING:** the supplementary contact can be used for different purposes (i.e. as a safety in order not to exceed maximum stroke in closing and opening, as an exclusion of the sensitive edge after the closing limit switch has been triggered, or for possible acoustic signals or traffic lights).

(Only DOD15) make sure that once triggered the opening and closing limit switches actually cause the door to come to a stop. If door continues moving, switch over the L1 and L2 power wiring in the control panel.

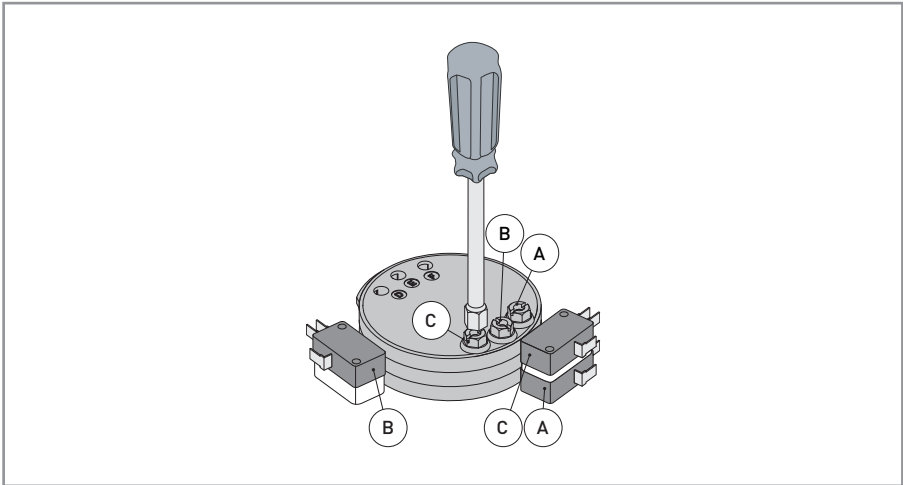

## 10.2 Ditec DOD 14PS electrical connections

With the provided push button the control panel isn't necessary, the automation works as "hold to run" function.

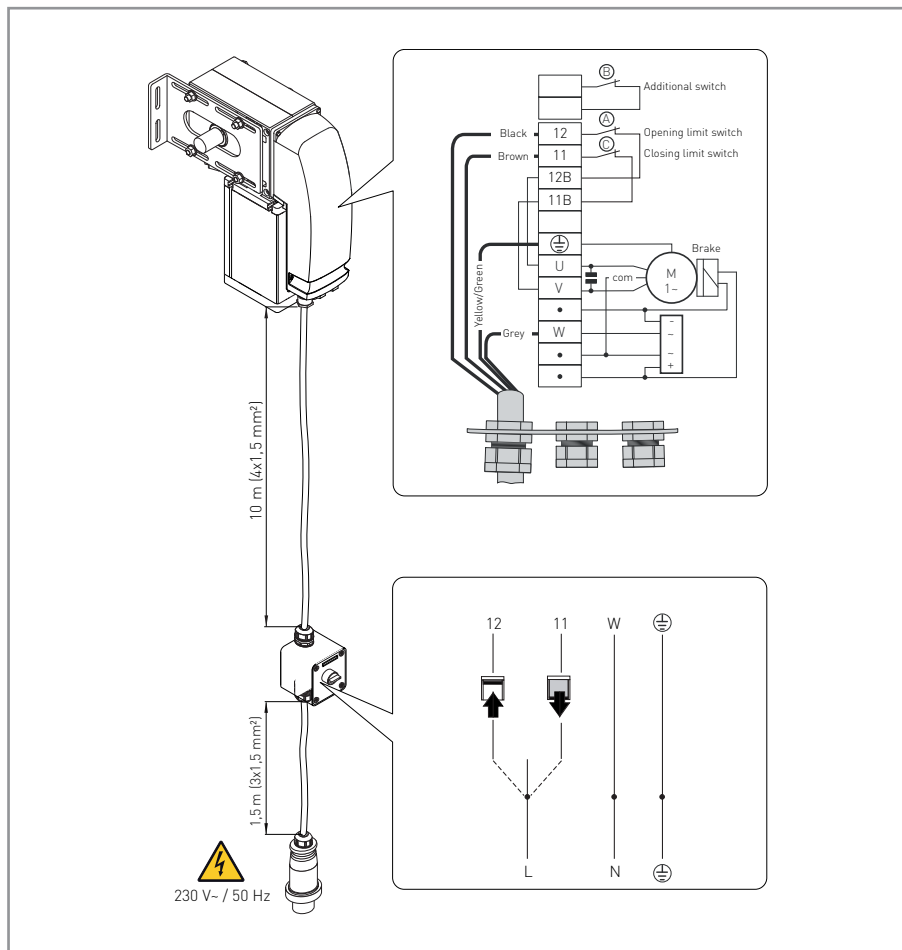

N.B.: If the power supply cable is damaged, refer to the spares price list and contact the Entrematic support service.

# 11. Routine maintenance plan

Perform the following operations and checks every 6 months according to intensity of use of the automation.

Disconnect the power supply, 230 V~ or 400 V~:

- Lubrication of mechanical parts must be performed with door down.
- Make sure that cable and spring breakage device is in perfect working order.
- Check lift-cable wear.
- Make sure that the cables run smoothly in the drums.
- Periodically grease the hinges, ball-bearings, wheel pins, and torsional springs.
- Check for any obstacles that may hinder the wheels from properly running in the guides.
- To check the correct balancing of the sectional automation.
- Make sure that the overhead sliding structure is firmly fastened to the ceiling and perfectly free from any defects, bending or buckling.
- Make sure that there are no loose bolts or screws.
- Absolutely avoid making any changes to the hoisting and/or sliding system.

Connect the power supply (230 V~ or 400 V~) and check that:

- Limit switches are working properly;
- All control and safety functions are in good working order.



NOTE: for spare parts, see the spares price list.



For repairs or replacements of products only original spare parts must be used.

The installer shall provide all information relating to automatic, manual and emergency operation of the motorised door or gate, and provide the user with operating instructions.

The installer must prepare the maintenance log, which will indicate all the interventions of ordinary and extraordinary maintenance carried out.

# Operating instructions

## General safety precautions for the user

 These precautions are an integral and essential part of the product and must be supplied to the user.

Read them carefully since they contain important information on safe installation, use and maintenance.

These instructions must be kept and forwarded to all possible future users of the system.

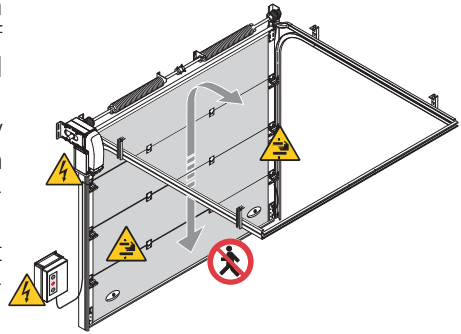

This product must only be used for the specific purpose for which it was designed. Any other use is to be considered improper and therefore dangerous.

The manufacturer cannot be held responsible for any damage caused by improper, incorrect or unreasonable use.

Avoid operating in the proximity of the hinges or moving mechanical parts. Do not enter within the operating range of the motorised door or gate while it is moving.

Do not obstruct the motion of the motorised door or gate, as this may cause a dangerous situation.

The motorised door or gate may be used by children over the age of 8 and by people with reduced physical, sensorial or mental abilities, or lack of experience or knowledge, as long as they are properly supervised or have been instructed in the safe use of the device and the relative hazards.

Do not allow children to play or stay within the operating range of the motorised door or gate.

Keep remote controls and/or any other command devices out of the reach of children, to avoid any accidental activation of the motorised door or gate.

In the event of a product fault or malfunction, turn off the power supply switch. Do not attempt to repair or intervene directly, and contact only qualified personnel.

Failure to comply with the above may cause a dangerous situation.

Any repair or technical intervention must be carried out by qualified



personnel.

Cleaning and maintenance work must not be carried out by children unless they are supervised.

To ensure that the system works efficiently and correctly, the manufacturer's indications must be complied with and only qualified personnel must perform routine maintenance on the motorised door or gate. In particular, regular checks are recommended in order to verify that the safety devices are operating correctly.

All installation, maintenance and repair work must be documented and made available to the user.

Only lock and release the door wings when the motor is switched off.

Do not enter within the operating range of the wing.

 To dispose of electrical and electronic equipment correctly, users must take the product to special "recycling centres" provided by the municipal authorities.



# Manual release instructions



**WARNING:** the sectional door may not be correctly balanced. The release operations and manual movement of the door should be carried out using the DODSBV handle release devices, or the DODSBC chain release devices.

In the event of a power supply failure or fault, to manually move the sectional, sliding or folding door you must:

- disconnect the power supply and stop the door;

## HANDLE RELEASE

- raise / lower the sectional door using the handle;

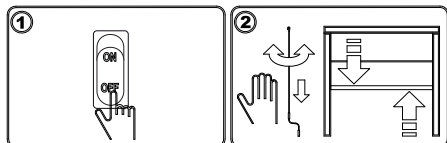

## CHAIN RELEASE

- raise / lower the sectional door using the chain;

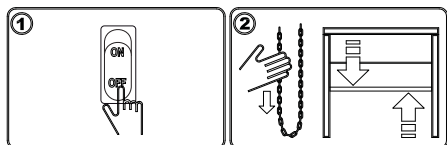

## CORD RELEASE

- push the door wing of the sliding or folding door and keep the cord release taut.

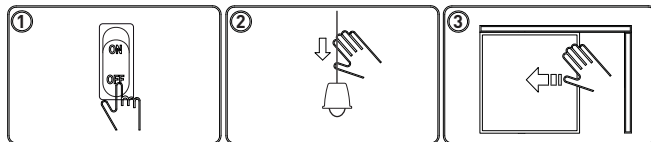

**WARNING:** the door wing block and release operations must be performed with the motor idle.



For any problems and/or information, contact the support service.

Installer's stamp	Operator
	Date of intervention
	Technician's signature
	Customer's signature

Intervention performed \_\_\_\_\_

\_\_\_\_\_

\_\_\_\_\_

\_\_\_\_\_

\_\_\_\_\_

\_\_\_\_\_

\_\_\_\_\_

Installer's stamp	Operator
	Date of intervention
	Technician's signature
	Customer's signature

Intervention performed \_\_\_\_\_

\_\_\_\_\_

\_\_\_\_\_

\_\_\_\_\_

\_\_\_\_\_

\_\_\_\_\_

\_\_\_\_\_



For any problems and/or information, contact the Technical Service.

**Entrematic Group AB**  
 Lodjursgatan 10  
 SE-261 44, Landskrona  
 Sweden  
 www.ditecentrematic.com

All the rights concerning this material are the exclusive property of Entrematic Group AB. Although the contents of this publication have been drawn up with the greatest care, Entrematic Group AB cannot be held responsible in any way for any damage caused by mistakes or omissions in this publication. We reserve the right to make changes without prior notice. Copying, scanning and changing in any way are expressly forbidden unless authorised in writing by Entrematic Group AB.

---

# ENTRE//MATIC



**Entrematic Group AB**  
Lodjursgatan 10  
SE-261 44, Landskrona  
Sweden  
[www.ditecentrematic.com](http://www.ditecentrematic.com)

